

**FINISH CODES**

**FILL IN SHADED AREAS TO COMPLETE THE PART DESCRIPTION**

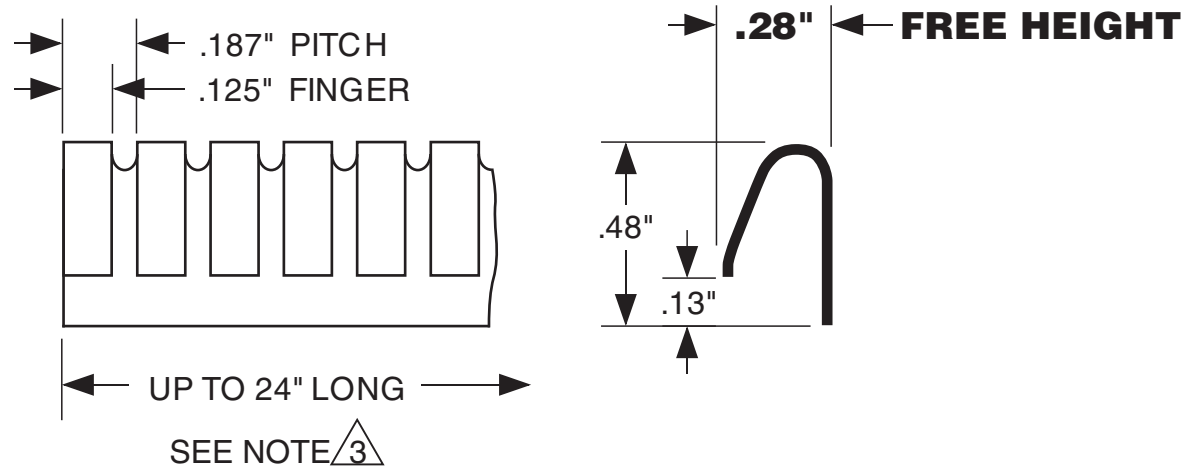

**TECH-ETCH MANUFACTURING PART NUMBER**

187H	-	-
(PROFILE)	-	(FINISH)
<b>LENGTH CALCULATOR FOR PART NUMBER ABOVE</b>		
CLICK HERE FOR STOCK LENGTH, OR ENTER NUMBER OF FINGERS HERE:		

**NOTES:**

1. MATERIAL .006" BeCu, C17200 HARDENED.
2. FINISH: AS SPECIFIED - SEE TOP LEFT.
3. STRIPS MAY BE SUPPLIED CUT TO ANY FULL FINGER INCREMENT.  
ALLOWED LENGTHS = NUMBER OF FINGERS MINUS SLOT WIDTH.
4. UNLESS OTHERWISE SPECIFIED DIMENSIONS ARE IN INCHES.

UNLESS OTHERWISE SPECIFIED ALL TOLERANCES TO BE: .XX ±.02 .XXX ±.005 .X ±.005/in.	 45 Aldrin Road, Plymouth, MA 02360 TEL 508-747-0300 • FAX 508-746-9639 sales@tech-etch.com • www.tech-etch.com
SCALE: <div style="text-align: center; font-size: 1.2em;">200%</div>	CATALOG PROFILE: <div style="text-align: center; font-size: 1.2em;">187H</div>
DATE: <div style="text-align: center; font-size: 1.2em;">5/1/03</div>	PART NAME: <div style="text-align: center; font-size: 1.2em;">Reverse Bend Contacts</div>
CUSTOMER PART NUMBER:	