

FINISH CODES

FILL IN SHADED AREAS TO COMPLETE THE PART DESCRIPTION

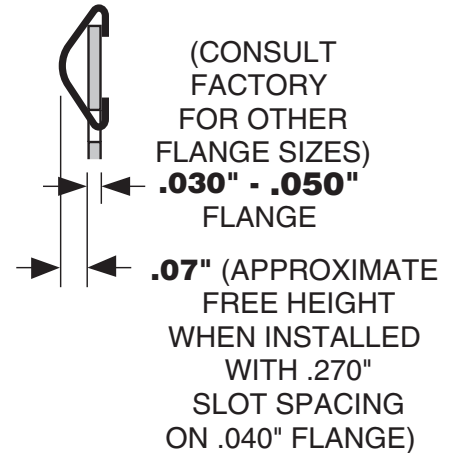

SELECT FINGER PATTERN DESIRED

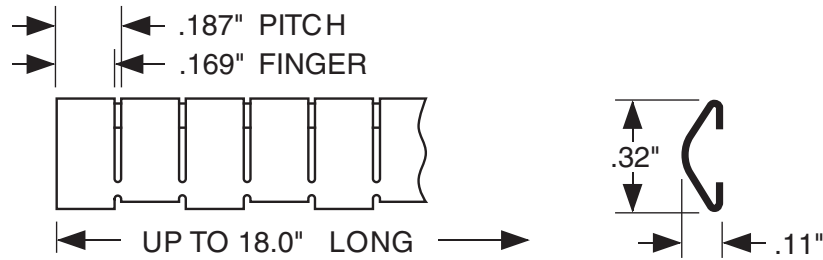
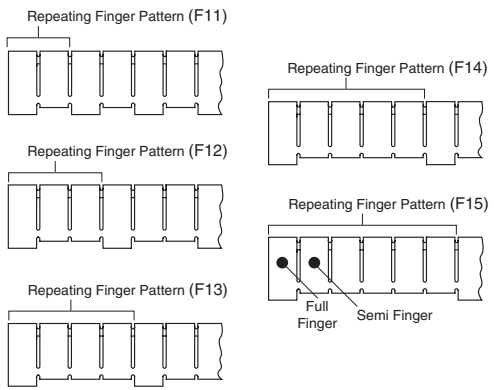

SEE NOTE ³
REPEATING FINGER PATTERN F11 SHOWN

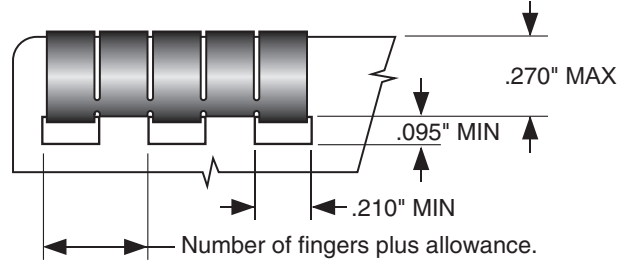

TECH-ETCH MANUFACTURING PART NUMBER

187VE32F	-	-
(PROFILE)	- (LENGTH)	- (FINISH)
CHOOSE STANDARD THICKNESS OR "TF" THICKNESS		
LENGTH CALCULATOR FOR PART NUMBER ABOVE		
CLICK HERE FOR STOCK LENGTH,		
OR ENTER NUMBER OF FINGERS HERE:		

NOTES:

1. MATERIAL .0035" BeCu, C17200 HARDENED.
2. FINISH: AS SPECIFIED - SEE TOP LEFT.
3. STRIPS MAY BE SUPPLIED CUT TO ANY FULL FINGER INCREMENT. ALLOWED LENGTHS = NUMBER OF FINGERS MINUS SLOT WIDTH.
4. UNLESS OTHERWISE SPECIFIED DIMENSIONS ARE IN INCHES.

UNLESS OTHERWISE SPECIFIED ALL TOLERANCES TO BE: .XX ±.02 .XXX ±.005 .X ±.005/in.	Tech-Etch 45 Aldrin Road, Plymouth, MA 02360 TEL 508-747-0300 • FAX 508-746-9639 sales@tech-etch.com • www.tech-etch.com
SCALE: 180%	CATALOG PROFILE: 187VE32F
DATE: 5/1/03	PART NAME: Snap-on Symmetrical Edge Mounting
CUSTOMER PART NUMBER:	