

FINISH CODES

FILL IN SHADED AREAS TO COMPLETE THE PART DESCRIPTION

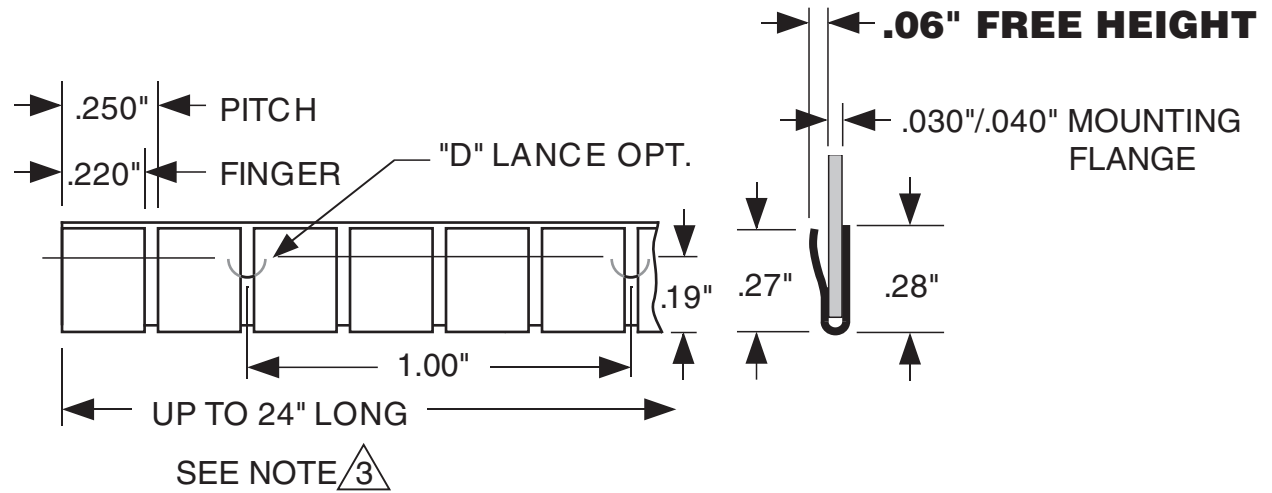

TECH-ETCH MANUFACTURING PART NUMBER

250C040	-	-
(PROFILE)	(LENGTH)	(FINISH)
CHOOSE	STANDARD THICKNESS OR	"TF" THICKNESS
LENGTH CALCULATOR FOR PART NUMBER ABOVE		
CLICK HERE FOR STOCK LENGTH,		
OR ENTER NUMBER OF FINGERS HERE:		

NOTES:

1. MATERIAL .006" BeCu, C17200 HARDENED.
2. FINISH: AS SPECIFIED - SEE TOP LEFT.
3. STRIPS MAY BE SUPPLIED CUT TO ANY FULL FINGER INCREMENT. ALLOWED LENGTHS = NUMBER OF FINGERS MINUS SLOT WIDTH.
4. UNLESS OTHERWISE SPECIFIED DIMENSIONS ARE IN INCHES.

UNLESS OTHERWISE SPECIFIED ALL TOLERANCES TO BE:

- .XX ±.02
- .XXX ±.005
- .X ±.005/in.

Tech-Etch

45 Aldrin Road, Plymouth, MA 02360
 TEL 508-747-0300 • FAX 508-746-9639
 sales@tech-etch.com • www.tech-etch.com

SCALE:

200%

CATALOG PROFILE:

250C040

DATE:

5/1/03

PART NAME:

Clip-on Low Profile

CUSTOMER PART NUMBER: