

**FINISH CODES**

**FILL IN SHADED AREAS TO COMPLETE THE PART DESCRIPTION**

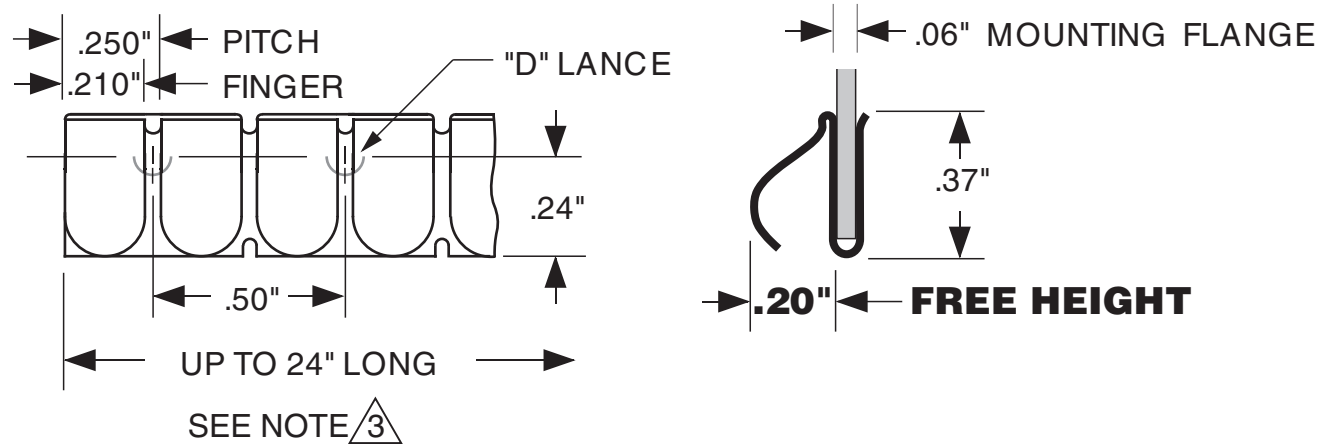

**TECH-ETCH MANUFACTURING PART NUMBER**

250KC070L	-	-
(PROFILE)	-	(LENGTH) - (FINISH)
<b>LENGTH CALCULATOR FOR PART NUMBER ABOVE</b>		
CLICK HERE FOR STOCK LENGTH,		
OR ENTER NUMBER OF FINGERS HERE:		

**NOTES:**

1. MATERIAL 005" .BeCu, C17200 HARDENED.
2. FINISH: AS SPECIFIED - SEE TOP LEFT.
3. STRIPS MAY BE SUPPLIED CUT TO ANY FULL FINGER INCREMENT. ALLOWED LENGTHS = NUMBER OF FINGERS MINUS SLOT WIDTH.
4. UNLESS OTHERWISE SPECIFIED DIMENSIONS ARE IN INCHES.

UNLESS OTHERWISE SPECIFIED ALL TOLERANCES TO BE: .XX ±.02 .XXX ±.005 .X ±.005/in.	<b>Tech-Etch</b> 45 Aldrin Road, Plymouth, MA 02360 TEL 508-747-0300 • FAX 508-746-9639 sales@tech-etch.com • www.tech-etch.com
SCALE: 200%	CATALOG PROFILE: 250KC070L
DATE: 5/1/03	PART NAME: Clip-on Reverse Bend Contacts
CUSTOMER PART NUMBER:	