

HIT ENTER AS YOU FILL IN THE SHADED AREAS TO COMPLETE THE STANDARD SHIELD DESCRIPTION

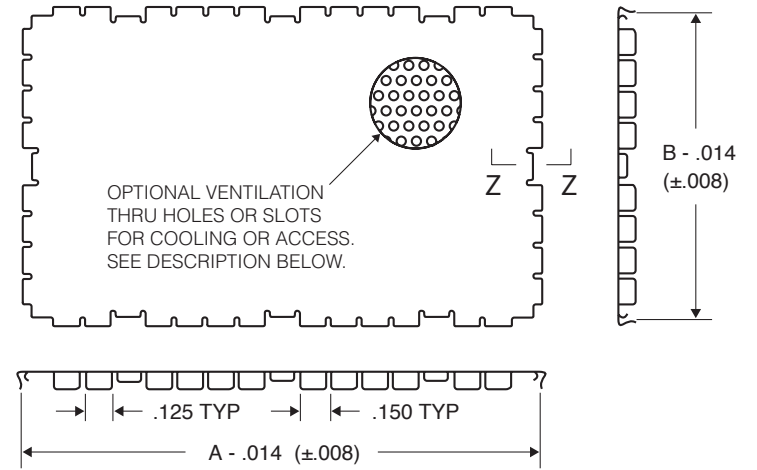
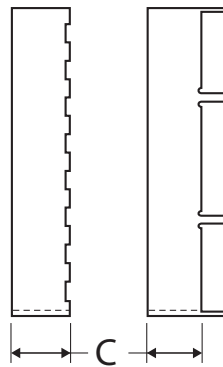
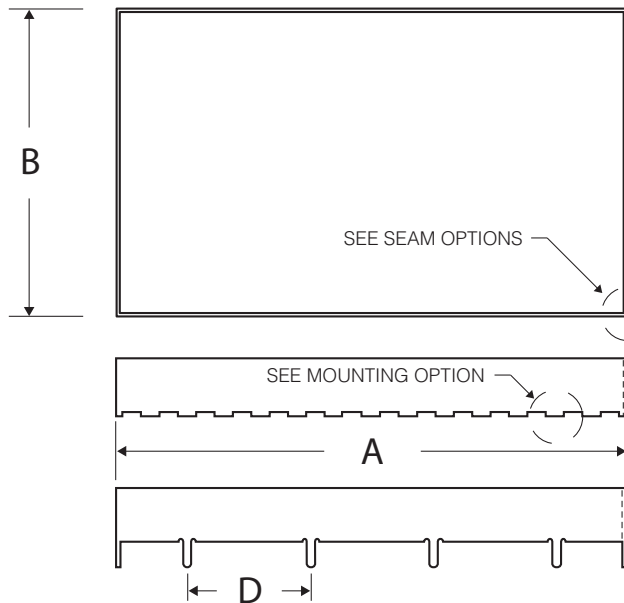

FILL IN DIMENSIONS		CLEAR
DIM A		
DIM B		
DIM C		
DIM D		
DIM E		
DIM F		

CHOOSE FINISH
Bright Tin
Matte Tin
Tin Lead

CHOOSE MATERIAL
Brass CDA 260
Steel 1010
Nickel Silver

CHOOSE MOUNTING OPTION	
STANDARD SURFACE MOUNT 	THROUGH HOLE MOUNT

CHOOSE SEAM OPTION		
NONE: NO WELD, SOLDER OR MECH. TAB 	WELD TAB 	SOLDER TAB

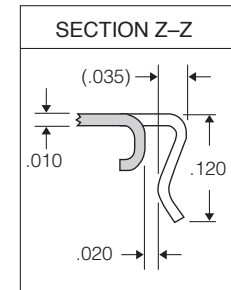

VENT OR ACCESS HOLES OR SLOTS	
NO	PLEASE DESCRIBE HERE:
YES	

DEPTH ETCHED PART NUMBER OR LOGO	
NO	PLEASE DESCRIBE HERE:
YES	

NOTES:

- MATERIALS: FENCE .015" 1/2 HARD BRASS, CDA 260;
COVER .010" FULL HARD BRASS, CDA 260.
- FINISH: 200-500 MICROINCHES, BRIGHT TIN PER ASTM B-545

THIS DRAWING IS FOR STANDARD TECH-ETCH BOARD LEVEL SHIELDS. OTHER CONFIGURATIONS AND OPTIONS ARE AVAILABLE. PLEASE CONTACT THE FACTORY FOR APPLICATION ASSISTANCE AND CUSTOM DESIGNS.

SUGGESTED SOURCE OF SUPPLY:
TECH-ETCH, INC.

<p>UNLESS OTHERWISE SPECIFIED: DIMENSIONS IN INCHES. TOLERANCES TO BE: .XX ±.015" .XXX ±.010" ANGLES ±3 DEG</p>	<p>Tech-Etch Tech-Etch, Inc. 45 Aldrin Road Plymouth, MA 02360 TEL 508-747-0300 • FAX 508-746-9639 sales@tech-etch.com • www.tech-etch.com</p>
	CUSTOMER / REF DOC:
	DESCRIPTION: STD. BOARD LEVEL SHIELD - FENCE/COVER
SCALE: NONE	CUSTOMER PART NUMBER:
DOC. REVISION DATE: HFI/10	