

FINISH CODES

FILL IN SHADED AREAS TO COMPLETE THE PART DESCRIPTION

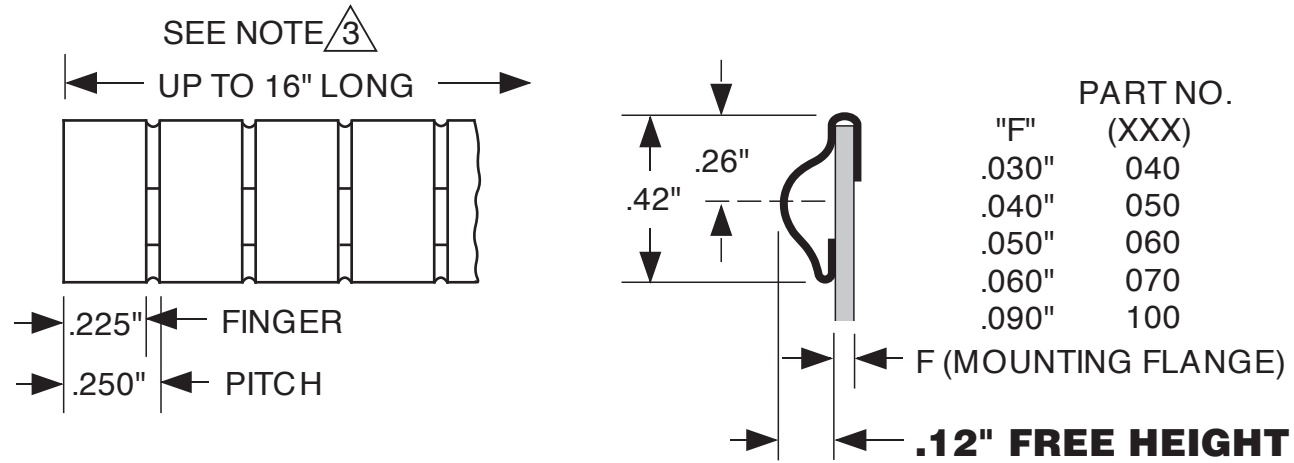

TECH-ETCH MANUFACTURING PART NUMBER

| | | |
|--|------------|------------|
| 250M42C | - | - |
| (PROFILE) | - (LENGTH) | - (FINISH) |
| CHOOSE STANDARD THICKNESS OR "TF" THICKNESS | | |
| LENGTH CALCULATOR FOR PART NUMBER ABOVE | | |
| CLICK HERE FOR STOCK LENGTH, OR ENTER NUMBER OF FINGERS HERE: | | |

NOTES:

1. MATERIAL .0035" BeCu, C17200 HARDENED.
2. FINISH: AS SPECIFIED - SEE TOP LEFT.
3. STRIPS MAY BE SUPPLIED CUT TO ANY FULL FINGER INCREMENT. ALLOWED LENGTHS = NUMBER OF FINGERS MINUS SLOT WIDTH.
4. UNLESS OTHERWISE SPECIFIED DIMENSIONS ARE IN INCHES.

| | |
|--|--|
| UNLESS OTHERWISE SPECIFIED ALL TOLERANCES TO BE: .XX ±.02 .XXX ±.005 .X ±.005/in. | Tech-Etch 45 Aldrin Road, Plymouth, MA 02360 TEL 508-747-0300 • FAX 508-746-9639 sales@tech-etch.com • www.tech-etch.com |
| SCALE: 200% | CATALOG PROFILE: 250M42CXXX |
| DATE: 5/20/09 | PART NAME: Clip-on No-snap Fingers |
| CUSTOMER PART NUMBER: | |