

FINISH CODES

FILL IN SHADED AREAS TO COMPLETE THE PART DESCRIPTION

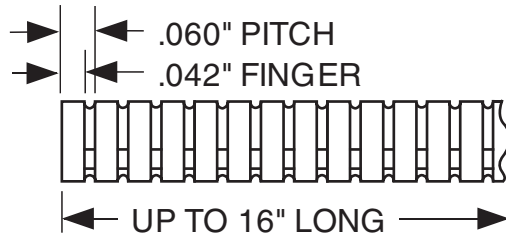

SEE NOTE ³

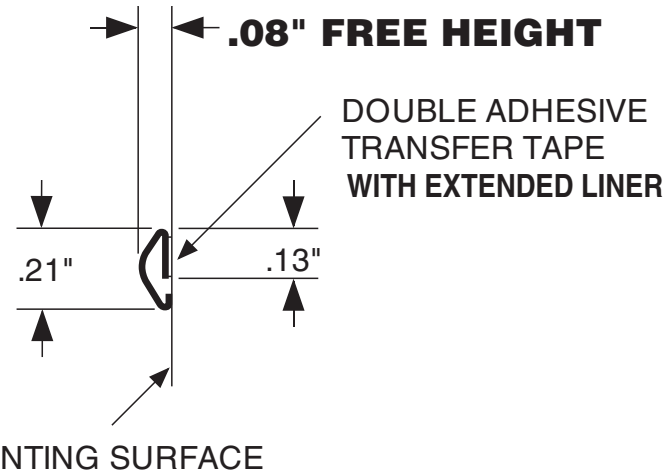

TECH-ETCH MANUFACTURING PART NUMBER

60P21 - -			
(PROFILE)	-	(LENGTH)	-
LENGTH CALCULATOR FOR PART NUMBER ABOVE			
CLICK HERE FOR STOCK LENGTH, OR ENTER NUMBER OF FINGERS HERE:			

NOTES:

1. MATERIAL .002" HEPÄVÖD ŠÒÙÀÙVÒÒŠ.
2. FINISH: AS SPECIFIED - SEE TOP LEFT.
- ³ STRIPS MAY BE SUPPLIED CUT TO ANY FULL FINGER INCREMENT.
ALLOWED LENGTHS = NUMBER OF FINGERS MINUS SLOT WIDTH.
4. UNLESS OTHERWISE SPECIFIED DIMENSIONS ARE IN INCHES.

UNLESS OTHERWISE SPECIFIED ALL TOLERANCES TO BE: .XX ±.02 .XXX ±.005 .X ±.005/in.	Tech-Etch 45 Aldrin Road, Plymouth, MA 02360 TEL 508-747-0300 • FAX 508-746-9639 sales@tech-etch.com • www.tech-etch.com
SCALE: 200%	CATALOG PROFILE: 60P21
DATE: 8/22/06	PART NAME: Stick-on Soft No-snap Fingers
CUSTOMER PART NUMBER:	